

Precision Rotary Table

FEATURES

- Compact Low-Profile Design
- Continuous 360° rotation
- 30mm through bore
- Dual high resolution encoders
- Precision index mark for homing
- Direct drive brushless servo motor

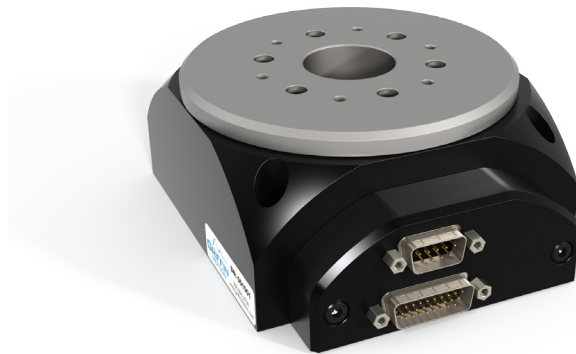

The RTS-DD Series Rotary tables are compact, direct drive, precision positioning tables designed for laboratory, factory automation and semiconductor processing equipment. The brushless direct drive technology eliminates backlash and improves reliability by eliminating sliding friction throughout the stage. The compact stage profile helps to minimize abbe error when used in conjunction with other motion axis. The bore allows convenient routing of vacuum or high voltage lines for a range of wafer chucks. Positioning resolution can be selected to meet the needs of the final application.



RTS-DD-100-M-D-S-U-0-00

Motion Specifications

Product Specifications

Angular Accuracy (arc-sec)	5
Angular Repeatability (arc-sec)	1
Angular Resolution (arc-sec)	0.324
Angular Velocity (deg/s)	480
Axial Runout (μm)	3
Continuous Torque (N-m)	0.75
Encoder Output	A quad B, index
Force X (N)	110
Force Y (N)	110
Force Z (N)	250
Height (mm)	55
Length (mm)	133
Limit Switches	No
Moment X (N-m)	10
Moment Y (N-m)	10
Moment Z (N-m)	0.7
Encoder Resolution (arc-sec)	0.324 (4000000cts/rev)
Peak Torque (N-m)	1.548
Radial Runout (μm)	3
Rotational Inertia ($\text{kg}\cdot\text{m}^2$)	0.001184
Stage Mass (kg)	2.32
Travel Range (deg)	360 continuous
Width (mm)	110
Wobble (arc-sec)	3

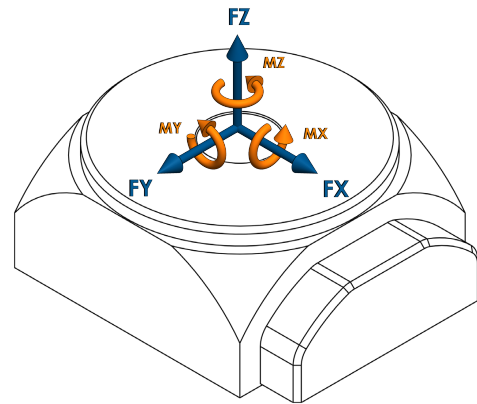

LOAD DIRECTIONS

Part Number Description

RTS	RTS Series
DD	Direct Drive
100	100mm Diameter
M	Glass Disk, 10000 Line Pairs
D	100X Interpolation
S	Stainless Steel Hub
U	Ultra High Precision
0	No Additional Options
00	Standard Product (Call for custom)

RTS-DD-100-M-D-S-U-0-00

Mechanical Specifications

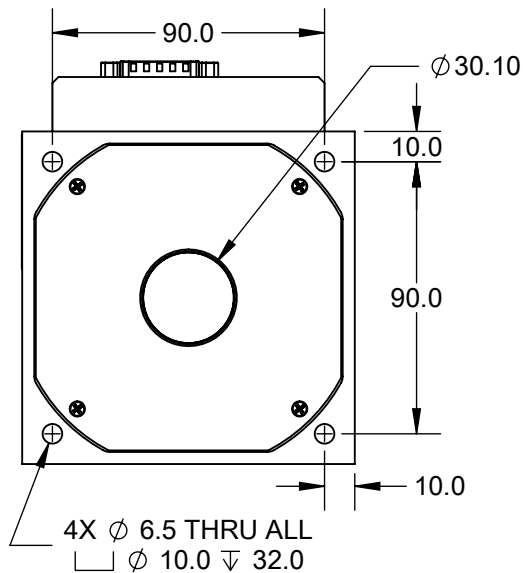
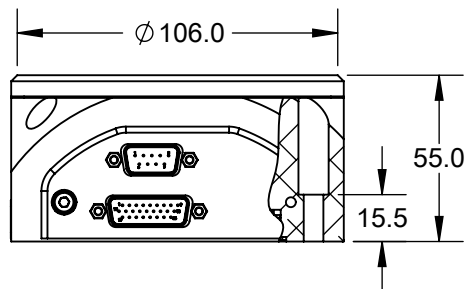
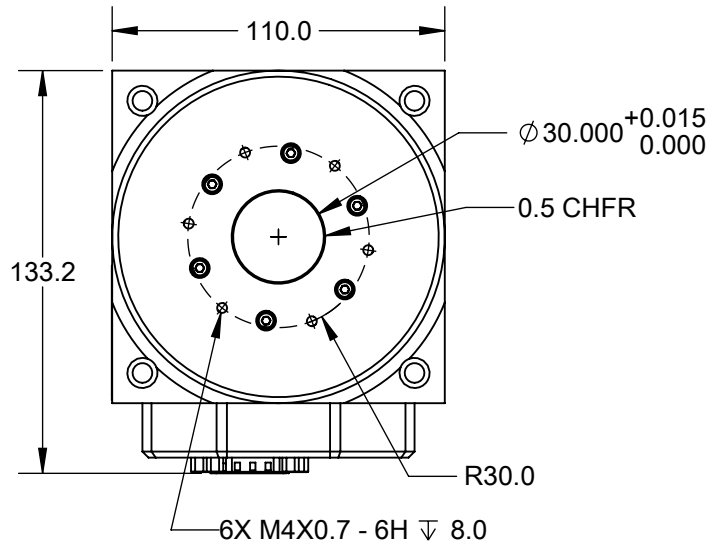

RTS-DD-100-M-D-S-U-0-00

Rev 9

Feedback Connector (DSUB26HD MALE)	
PIN	NAME
1	+5V
2	A+
3	B+
4	Z+
5	*
6	ERR+
7	*
8	*
9	*
10	*
11	A-
12	B-
13	Z-
14	*
15	ERR-
16	*
17	*
18	*
19	GND
20	HALL A
21	HALL B
22	HALL C
23	*
24	*
25	*
26	*
* Reserved	

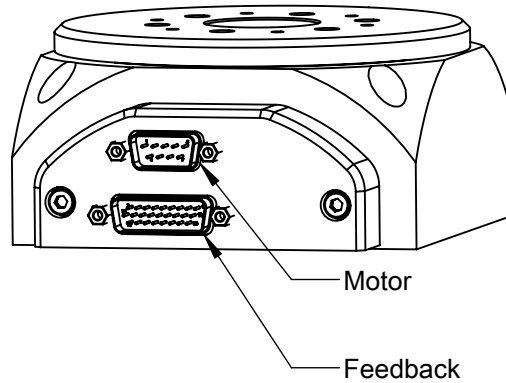

Motor Connector (DSUB9 MALE)	
PIN	NAME
1	*
2	*
3	*
4	*
5	*
6	PHASE A
7	PHASE B
8	PHASE C
9	*
* Reserved	



Motor Specifications	
Motor Type	3 Φ Brushless DC
BEMF Constant (V/KRPM)	20.685
Electrical Time Constant (ms)	0.882
Max Bus Voltage (VDC)	100
Max Continuous Current (A)	3.980
Motor Torque Constant (N·m/A)	0.198
Peak Current (A)	7.838
Pin to Pin Inductance (mH)	2.308
Pin to Pin Resistance (ohm)	2.616
Poles per Revolution	12

Feedback Specifications	
Supply Voltage (V)	5.0 \pm 10%
Supply Current (mA)	250
Encoder Feedback	Yes
Encoder Type	Incremental
Encoder Output	Square Wave Quadrature, RS-422 compatible, A,B,Z, Differential Pairs
Hall Switch Output	Open-Collector, No Pullup Resistor
Hall Switch max current (mA)	-20
Limit Switches	No
Error Output	CMOS
Error Output max current(mA)	\pm 20

The encoder has one index mark. It will output a pulse once per revolution when this index mark is passed. This pulse is highly repeatable and can be used to find an absolute position (within one revolution of the output shaft) upon power-up.

An Error output will provide a pulse if there is an error in interpolation. This can be caused by a shaft speed that is too high or by the encoder signal dropping below a preset threshold. In normal operation with no error, this output will be high.